

Straightcurve® Flex Garden Edging - 150mm

FL150WS WEATHERING STEEL | FL150GS GALVANISED STEEL

EDGE STYLE



FINISHES

- Galvanised Steel
- Weathering Steel

For smoothly curving edging applications that hold position once shaped and installed.

Product features

The details that make the difference



Connector plate and guide holes for precise and discreet joints

8mm Rounded Tops for child and pet safety

Double Rolled, Notched Top for smooth, even curves

Discreet presence for retrofits and design integrity

Moveable Lock-in Peg for easy obstacle avoidance

Product specifications

TECHNICAL SPECIFICATIONS

Length (Installed)	2200mm
Top edge thickness	8mm
Steel plate thickness	1.6mm
Weight per length	5.4kg

BULK BUYING

Pack quantity	50
Bulk pack weight inc. pallet	290kg

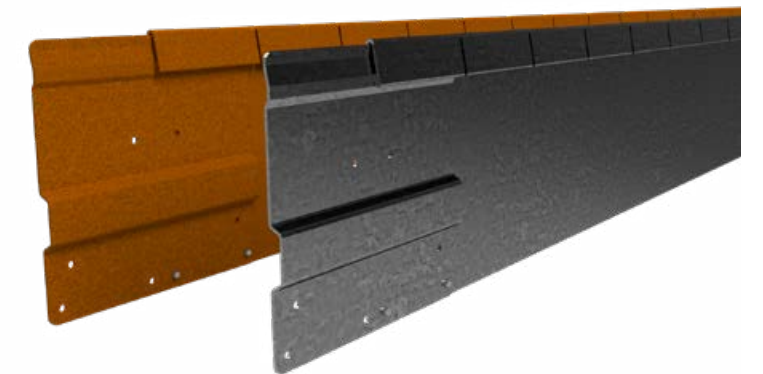

SOLD AS SET INCLUDING

- 1 x Connector plate (pre-attached)
- 3 x Fixing pegs, 300mm long



ADDITIONAL ACCESSORIES

- 500mm Corner piece (250 + 250mm arms, bend to desired angle)
- Hard surface fixing bracket
- Heavy duty peg

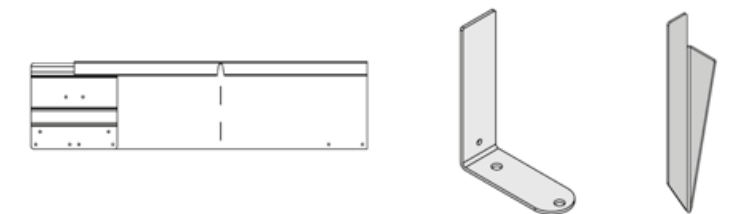

150mm Flex Installation Guide



REQUIRED FIXINGS

- 2 x Tek Screws (12G x 16mm) or
- 2 x pop rivets (4mm shaft)

RECOMMENDED TOOLS

- Ground leveling tools
- Rubber mallet
- Cordless drill and Tek screw bit
- Angle grinder (only required if modifying lengths or fashioning ends)

PREPARATIONS

Making a trench to set the edge into is usually necessary. This will dictate the amount of edge that finishes proud and visible for your buried edge. For a retrofit, where surrounding heights are set, trench relative to these. For a new garden where surrounding materials may be added, the edge is sometimes installed without a trench, and then materials are filled up to and around it. Either way, burying the edge more deeply adds strength and assists curve support, consider the 240mm edge if more visibility of edge face is desired.

Note: This edge allows gentle sloping. Corners can be made or purchased as accessories. Length excess is cut away with angle grinder tool.

DO...

- ✓ Consider the best edge orientation in terms of smooth face/top edge viewing
- ✓ Join all lengths in place and perfect the line before finally fixing in position.
- ✓ Use some pegs to hold partially in place while reviewing position
- ✓ Flex rather than bend, especially if creating rings
- ✓ Use some Rigid lengths if your design has some straight sections, they have compatible connectors!

DON'T...

- ✗ Use for straight lines, instead use Rigid or Zero-Flex
- ✗ Forcibly bend. Take care and gently flex the edge to shape
- ✗ Accelerate rust with acids or salts, that's harmful to patina development
- ✗ Leave a square top corner unsafely protruding at an end, cap or round it off with a grinder instead.

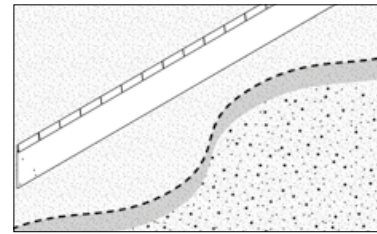

STEP 1 - Mark edge line on ground or by trenching and layout edge pieces.

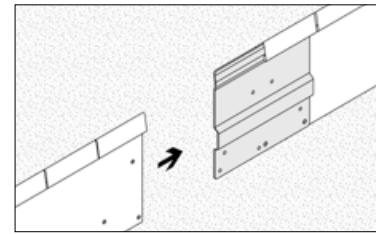

STEP 2 - Slide connector plate of one into the next to connect.

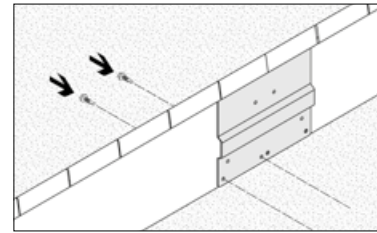

STEP 3 - Secure together with Tek screw through aligned guide holes.

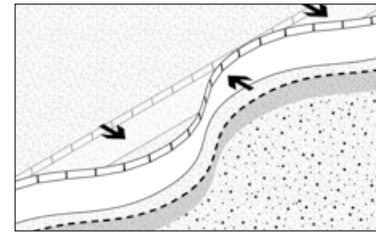

STEP 4 - Place, flex and connect all lengths along line, check line using pegs as temporary placeholders if needed.

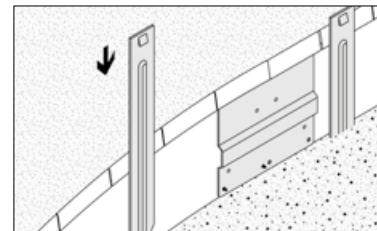

STEP 5 - With line just right, hammer all pegs adjacent edge (three per length) leaving them just above finishing height.

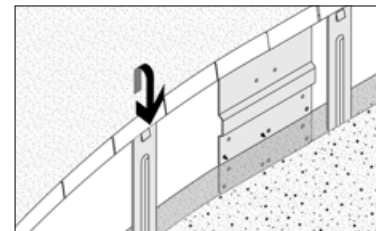

STEP 6 - Place edge onto pegs and use rubber mallet to hammer edge on so peg locks in. Work down the line.

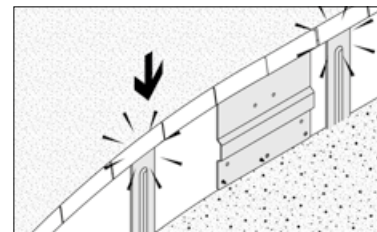

STEP 7 - Firming can be done with the rubber mallet.

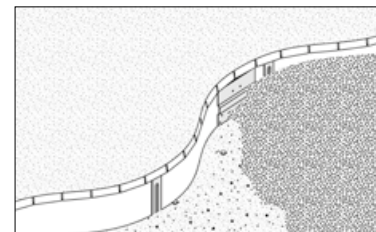

STEP 8 - Backfill to finish.

CORNERS

Standard corners are available for purchase, but you can choose to make your own. Making your own corners will likely mean less waste, as the corners are simply made where they are needed with no offcuts created.

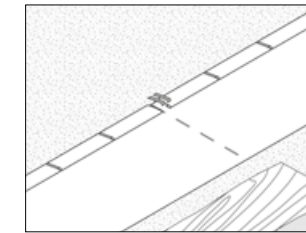

STEP 1 - Score a line down the back of the edge and create a sufficient opening (5-7mm) in the double folded lip at the top.

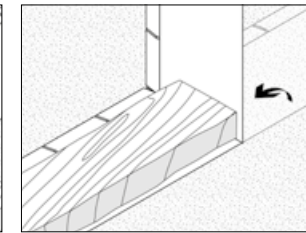

STEP 2 - Bend by hand. Placing a block of wood close to the fold improves the result.

JOINING EDGE TO A SURFACE OR ROCK

A join tab can be made using an angle grinder. This involves cutting away the top lip portion and scoring a fragmented fold line for the remaining tab piece. The tab is then bent as required for fixing and screwing to the surface it joins.

If butting up to a rock, using a diamond tip blade to cut a slot in the rock itself allows the edge to sit into it snugly, or just use the rock to hide the edge end safely behind it.

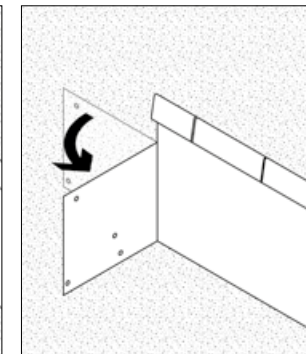
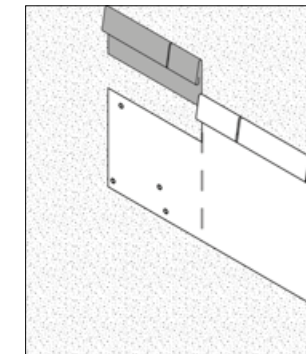

INSTALLING ON HARD SURFACES

Where ground conditions are too hard for standard pegs to penetrate, the Heavy Duty Peg may be used instead. These are first driven into the ground (hammer the hip, not the top part) and then the edge is hammered onto them with a rubber mallet to firmly wedge the Heavy Duty Peg in under the edge rim.

Alternatively the Hard Surface Fixing Bracket may be used. This also wedges firmly in under the edge rim when the edge is hammered onto it with a rubber mallet. This Hard Surface Fixing Bracket can be secured through the holes in the foot with galvanised spikes in hard ground or with DynaBolts™ when fixing to concrete. The DynaBolts™ or Fixing spikes utilised do not come with the bracket so need to be acquired separately.

On impermeable surfaces such as concrete, use packers to elevate the edge slightly; allowing drainage away from edge.

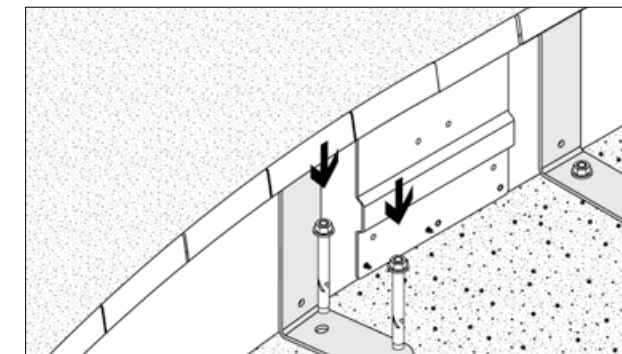
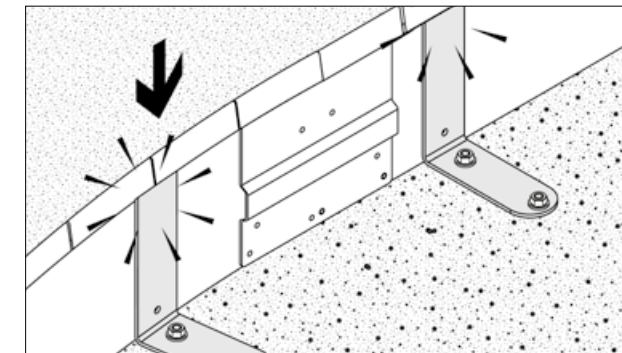

150mm

150mm

CIRCLES & TIGHT CURVES

One length makes a tight 70cm diameter circle. Take care to gently flex the edge (i.e. do not bend) when forming the ring. Once the connector plate is aligned, Tek screw through the guide holes, then carefully adjust ring shape to your liking and fix to ground.

The tight ring made with one length is not completely smooth on the inside. You can add part of a length (which requires cutting) to get a smoother result. Using whole lengths only the diameters increase with each additional length, i.e. 141cm, 212cm, 283cm and so on.

As a guide the tightest curves without kinking the steel is equivalent to a radius of around 35cm. A further tip to achieve a tighter curve is to use your angle grinder to cut additional notches into the top lip in the section where it's needed.

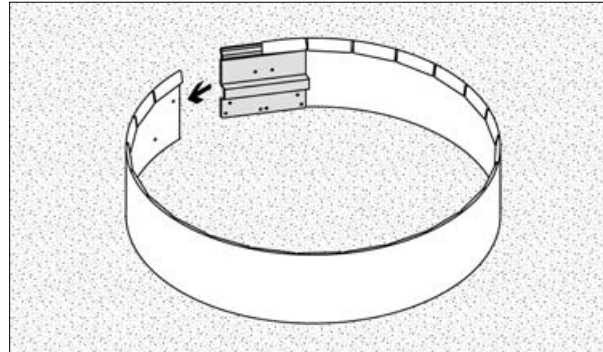

COMPATIBILITY

The 150mm Flex is compatible with the 150mm Rigid, because the joining plates and edge profile are exactly the same. This means you can use both together on the same project!

