

Straightcurve Flex Raised Garden Bed Panel - 240mm

FL240WS WEATHERING STEEL | FL240GS GALVANISED STEEL

EDGE STYLE



FINISHES

- Galvanised Steel
- Weathering Steel

For smoothly curving Raised Garden Beds that look great and hold position once shaped & installed.

Product features

The details that make the difference

Wedge and slider join system for a faster, stronger no weld method

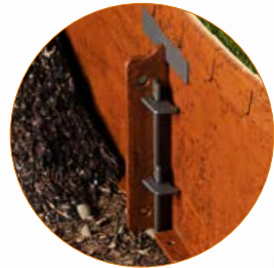

Full face visible instead of burying the edge. Discreet join seams for a stylish finish



Moveable fixing spikes for easy obstacle avoidance



Notched Top and Foot for smooth, even curves



8mm rounded tops for child and pet safety

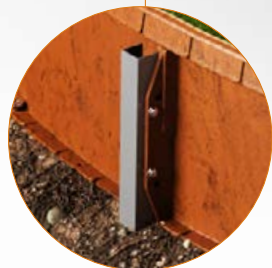

Ribs and anchor posts for strong vertical staking



Product specifications

TECHNICAL SPECIFICATIONS

Length (Installed)	2160mm
Top edge thickness	8mm
Steel plate thickness	2mm
Weight per length	10kg

BULK BUYING

Pack quantity	30
Bulk pack weight inc. pallet	320kg

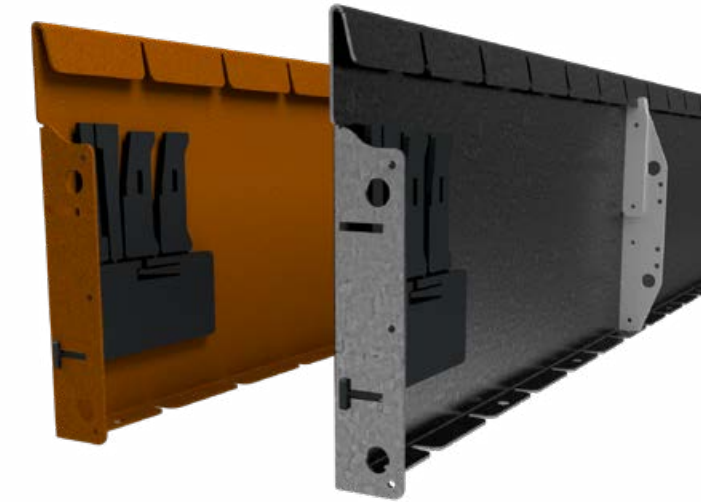

SOLD AS SET INCLUDING

- Joining set includes 1 X join bracket (A), 2 x slider (B), 2 x wedge (C)
- 5 x Fixing spikes, galvanised, 300mm long
- 2 x bracing ribs (attached to edge)

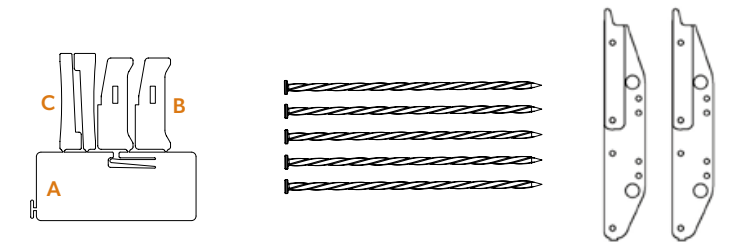

ADDITIONAL ACCESSORIES

REQUIRED

- D** Ground anchor post 470mm, use 2 per length (Tek screws required)

OPTIONAL

- E** Corner piece (90 degree right angle/arm lengths: 255mm)
- F** Reverse corner piece (270 degree L-shape/arm lengths: 255mm)
- G** Universal bracing set as ground anchor post alternative (turnbuckle/chain/T-stake)
- H** Join Part for Offcuts (Tek screws required)

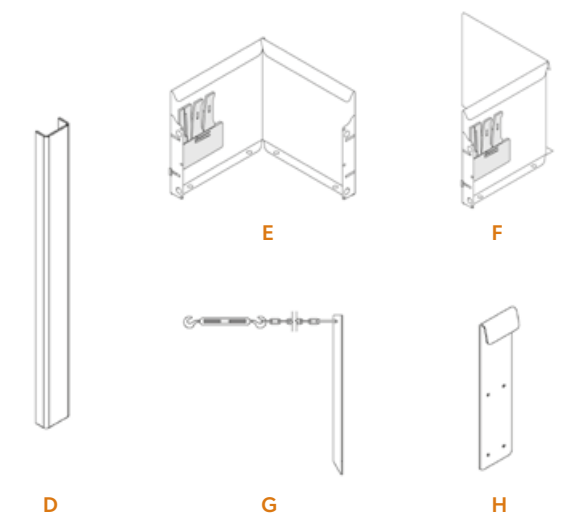

Flex Raised Garden Bed Panel - 240mm Installation Guide

Scan or click to watch install video

▶ INSTALL GUIDE



REQUIRED FIXINGS

- Ground anchor post
2 x Tek Screws (12G x 16mm)
- Join part for offcuts
6 x Tek Screws (12G x 16mm)

RECOMMENDED TOOLS

- Ground leveling tools
- Metal hammer
- Rubber mallet
- Cordless drill and Tek screw bit (for accessories **D** and **H**)
- Angle grinder (required if modifying lengths or fashioning corners/ends)

PREPARATIONS

The Flex Raised Garden Bed requires NO digging in as its feet are secured to the ground surface. The base should be smoothed/ leveled for the edge to sit flush on the ground during installation. Any obstructions should be removed or re-routed. It can be installed on all level ground types including concrete surfaces (where packers are used to sit edge off ground to allow drainage). It is useful to have some cardboard or board to place under joins when connecting with the panel face down on flat ground. Grass and debris likes to get caught in the tight seam!

DO...

- ✔ Join all lengths in place and perfect the line before finally fixing in position.
- ✔ Use the rubber mallet (not metal hammer) when hammering top edge
- ✔ Start from corner if using a pre-made one
- ✔ Score an intermittent line rather than one deep score line if making corners.
- ✔ Follow the instructions carefully and do it with a friend if making a two panel ring
- ✔ For circular beds backfill evenly for equal outward pressure

DON'T...

- ✘ Use for straight lines, instead use Rigid or Zero-Flex options
- ✘ Forcibly bend. Take care and gently flex the edge to shape
- ✘ Forget to stake or brace your edge once joined (unless a circle of four lengths or less)
- ✘ Accelerate rust with acids or salts (but soapy water is ok!)
- ✘ Leave a square top corner unsafely protruding at an end, cap or round it off with a grinder instead.

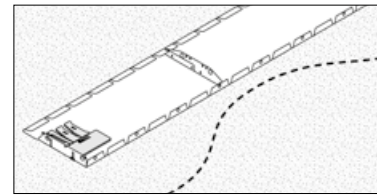

STEP 1 - Mark edge line on ground and layout edge pieces nearby.

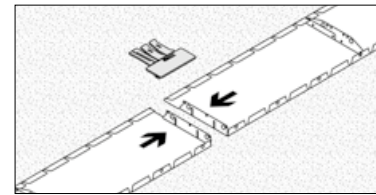

STEP 2 - Place first two edges front face down on the ground with ends touching and with join slots aligned.

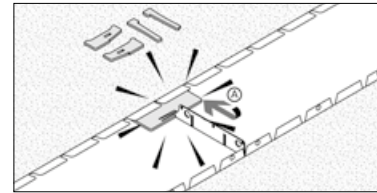

STEP 3 - Join using the joining set, break the pieces apart first by hand and insert join bracket (A) securely under the top lip (centered). Press it against back of panels (use a metal hammer to firmly lock in).

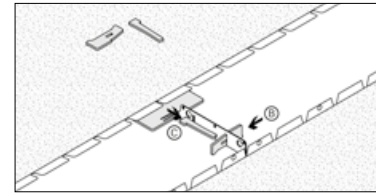

STEP 4 - Next, insert a slider (B) through adjacent bottom slots with its 'feet' against the edge. Knock it through fully so wedge (C) can insert and lock in the slider.

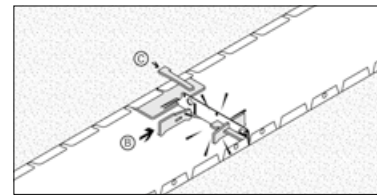

STEP 5 - Hammer the wedge in firmly. Repeat step 4 for top slot using the remaining wedge and slider.

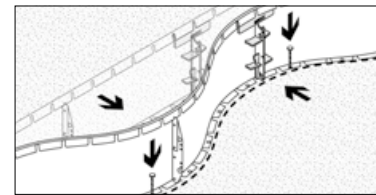

STEP 6 - Set these two edges upright and flex to position where desired, use fixing spikes as temporary placeholders.

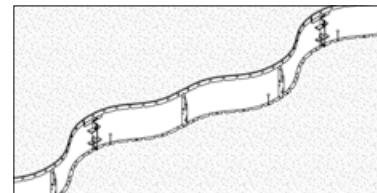

STEP 7 - Introduce and join further lengths (or joined pairs of lengths), butting them against the now standing edge, connecting them as you go.

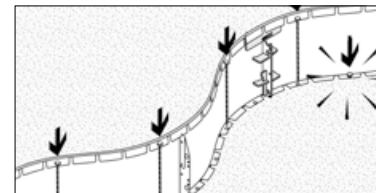

STEP 8 - Check the line, then hammer all fixing spikes (5 per length) through foot tab holes.

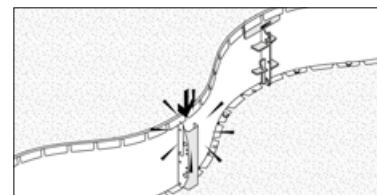

STEP 9 - To Stake, hammer the ground anchor post in tightly adjacent a bracing rib and close against the bottom foot.

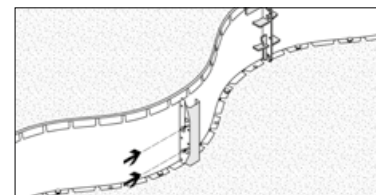

STEP 10 - Screw the ground anchor post to the bracing ribs with tek screws through guide holes.

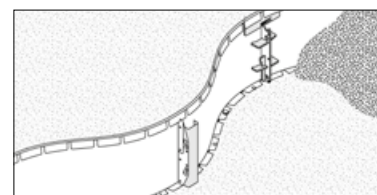

STEP 11 - Back fill your Raised Garden Bed to finish.

Creating corners

PRE-MADE CORNERS

Pre-made corners with 255mm long arms are available for purchase and include the standard joining set. There is a standard 90 degree right angle corner and a reverse corner for turn backs such as when making an L-shape. It's difficult, but the angle of these pre-made corners can be adjusted by applying considerable force using ratchet straps or other means.

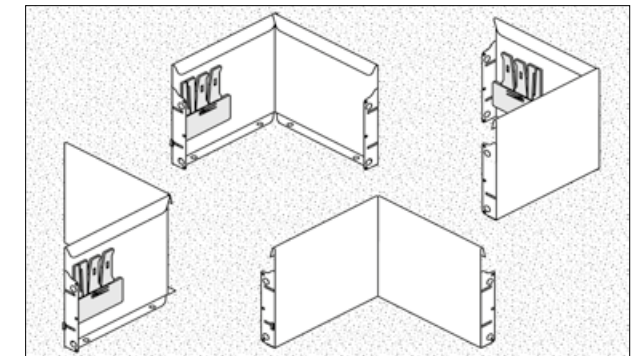

MAKING YOUR OWN CORNERS

To make a corner yourself you will need to use an angle grinder. Be sure to operate safely with all suitable gear.

1. Mark a vertical line down the back of the edge directly beneath a top edge notch space where the corner fold is needed. With the angle grinder score the line in three places sufficiently to create a fold line.
2. Also widen the top lip notch gap and cut and remove a bottom foot tab on one side of the fold line to allow room for bending in.
3. Bend strongly by hand; using a block of wood close to the fold to form the bend against helps.

For reverse corners (~270°) a fold line will need to be cut in as above. Also raise the height of the notch groove to the top of the lip neatly to aid the bend. No other cuts are required.

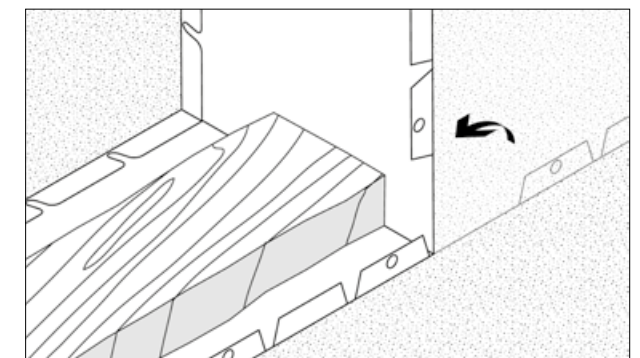
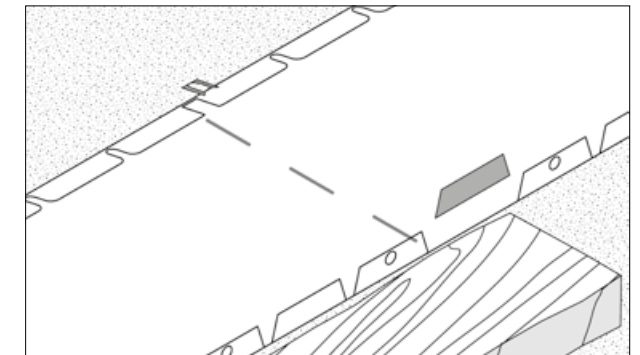

240mm

240mm

Creating circles

CIRCLES & CURVE CAPABILITIES

Connecting edge panels makes standard ring sizes. Design for complete edge lengths of 2 or more to give the desired diameter. Here's our standard sizes.

Standard Circle diameters

No. of panels:	2	3	4	5
Diameter:	1.37m	2.06m	2.75m	3.44m

In terms of curve capabilities, the 240mm Flex Raised Garden Bed Panel has a minimum radius achievable of around 700mm. It is designed to allow this degree of flex and no more. This is also why you cannot make a ring with one panel, the two panel ring is the smallest possible. If the Raised Garden Bed face makes a concave curve the back of the join flanges can gap slightly. To counter this, there are some pilot holes at the back edge of the join flange. Screw through these with Tek screws before creating the concave curve.

HOW TO MAKE A TIGHT CIRCLE (D:1370MM) WITH TWO EDGE PANELS.

Require 5m ratchet strap and sturdy rectangular board (recommend 600-1200mm wide X edge height). This construction is best done with two people.

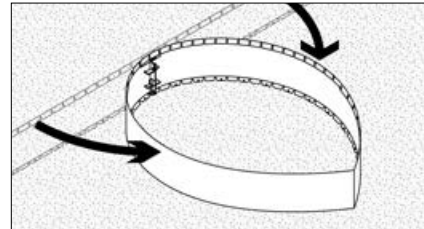

STEP 1 - Connect two panels with joining set, then pull ends in to meet in teardrop shape.

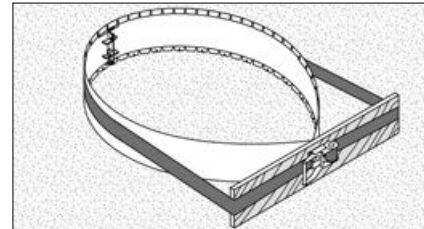

STEP 2 - Place ratchet strap around midriff and over the board, with the board positioned to pull in open end.

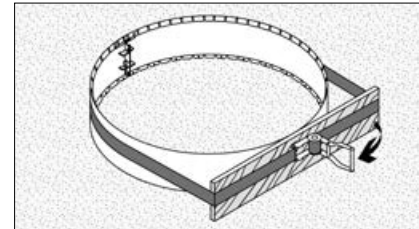

STEP 3 - Ratchet in until ends are flush, and fully align join flanges with gradual ratcheting.

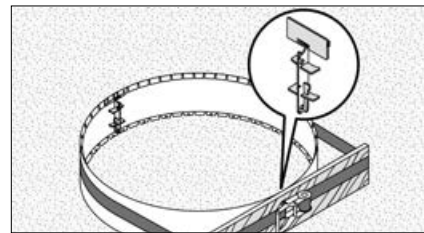

STEP 4 - When the edge end joint flanges align perfectly, use joining set to lock together.

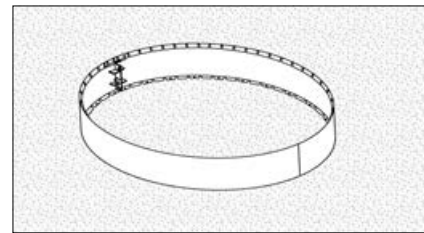

STEP 5 - Release ratchet and unstrap, it will be slightly oval in shape.

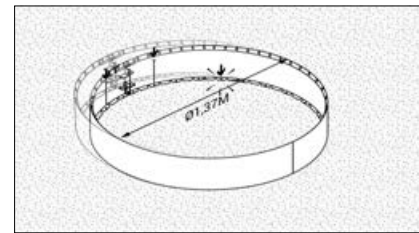

STEP 6 - Correct to desired ring shape, measuring diameter (1.37m) and pin the feet to hold as you go.

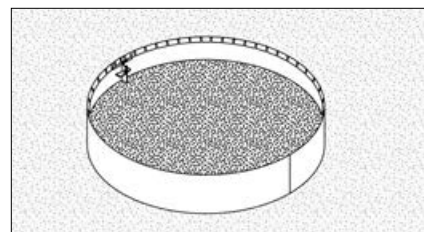

STEP 7 - That done, fill evenly, there is no need for bracing this self supporting circle.

Note: For three or more panels, two people can simply pull into shape and connect, without the need for ratchet approach

Bracing methods

BRACING ON VARIOUS HARD SURFACES

The 470mm ground anchor posts will not be strong enough to penetrate some surfaces. In these situations use the Universal Bracing Sets by fitting the turnbuckle with chain to the pre-fitted bracing ribs and anchoring back to the ground.

1. The stake that comes with the Universal Bracing Set is of a star picket style and will penetrate very hard surfaces, as do the fixing spikes that lock in the feet.
2. On concrete, a bolt down method can be used in place of the stake, anchoring the chain with a DynaBolt™. Bolt the foot tab holes in place with an 8mm DynaBolt™, but first introduce packers to raise it slightly for drainage.

TIP: When using the Universal Bracing Sets, securing the anchor point to alternative structures such as walls or fences is also a workable solution.

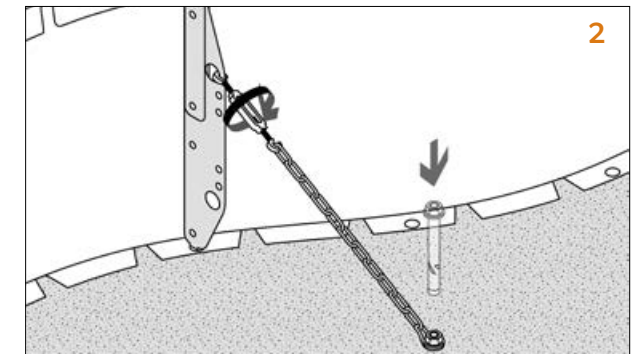
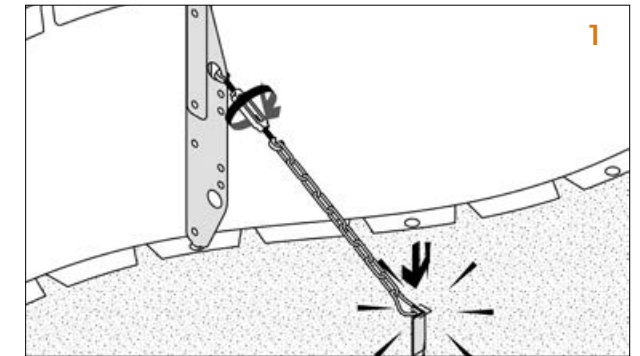

HOW TO MOVE A BRACING RIB

It's easy to move the bracing rib if it is located above an obstacle preventing staking there or where access to the rib will be difficult. Simply loosen and remove the bracing rib by knocking it sideways near the top with a hammer. It can then be refitted in a new place, inserting the base nub into a bottom foot tab hole first, and then tapping the upper part of the bracing rib with a hammer firmly to return it to a vertical position tight behind the top lip.

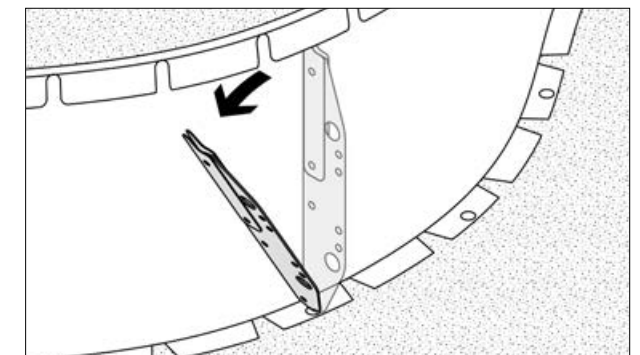

CREATING CONNECTION TABS OF YOUR OWN

To fix one end to a wall or other solid feature you can fix the folded back flange on the end of the panel to that surface. Simply bolt or screw as appropriate to fix it strongly.

If the edge panel is too long to do that, you can both shorten and create a join tab at the same time with your angle grinder. To do so measure carefully first, then remove the extra top lip portion and create the fold back piece by the score and bend method as shown. The tab can then be screwed internally to the surface it meets, which is sometimes another piece of Straightcurve®!

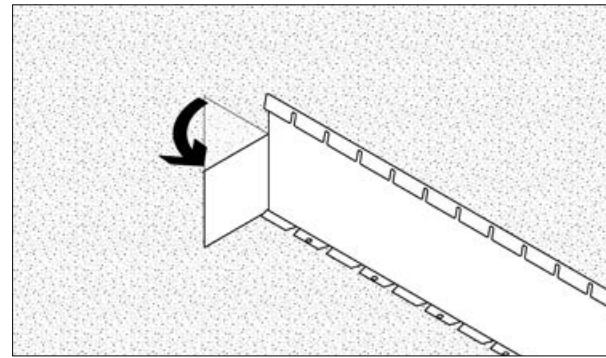
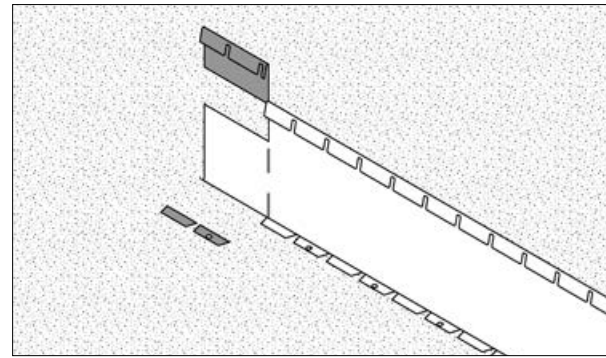

COMPATIBILITY AND WORKING ON SLOPES

1. The 240mm Flex Raised Garden Bed Panel is compatible with the 240mm Rigid Raised Garden Bed Panels. This allows them to work in combination.
2. In fact, join slots align across all Flex or Rigid panels (240/400/560mm) so that a continuous top edge occurs if different heights are joined together. This across height compatibility can be used to advantage with Raised Garden Beds on a slope. On the lower part of the slope the Raised Garden Bed run may need taller panels with a greater edge face visible due to the slope falling away, with panels of lesser height required further up the bank. It takes some careful planning, but can look very effective, adding volume and height to a bed while reducing the amount of steel used in the project overall.

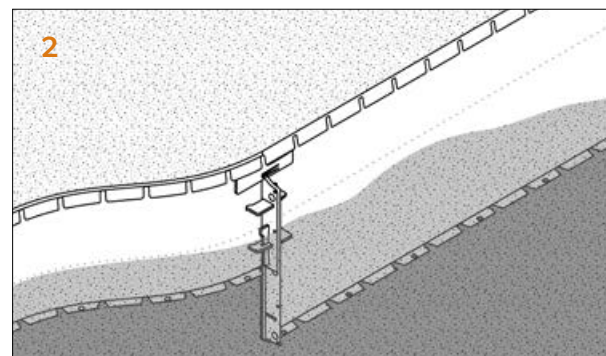
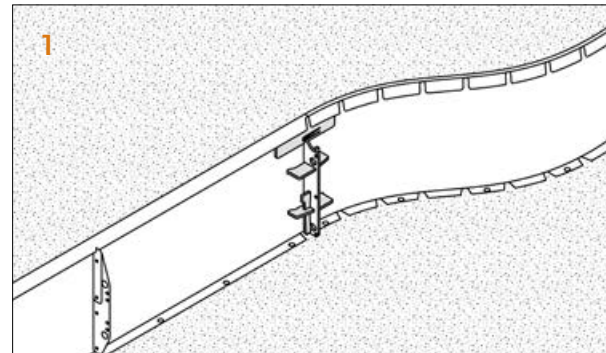

HOW TO USE A CUTBACK PANEL

When a panel is shortened with an angle grinder it loses the join flange. To solve that problem we have a Join Part For Offcuts. This is simply screwed to the cutaway end (through guide holes in join part) and overlays the length it is joining. Further screwing sees both panels neatly connected.

This overlay Join Part does mean screws are visible on the face of the Raised Garden Bed, but it is helpful with perimeters that require a part length to meet or when making regular shaped beds where the side length is predetermined. It also means no offcuts are wasted!

Some tips here are to either place the join part in the least conspicuous spot and use Zinc Screws which blend in as they rust over (for Weathering Steel), or make a feature of it by adding more Join Parts to create a pattern. With that approach, you may even choose to substitute polished bolt heads in place of the discreet screws.

