

Straightcurve® Zero-Flex Garden Edging - 75mm

RL075WS WEATHERING STEEL | RL075GS GALVANISED STEEL

EDGE STYLE

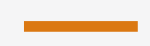

FINISHES

- Galvanised Steel
- Weathering Steel

For creating straight lines that look good down the line.

Product features

The details that make the difference

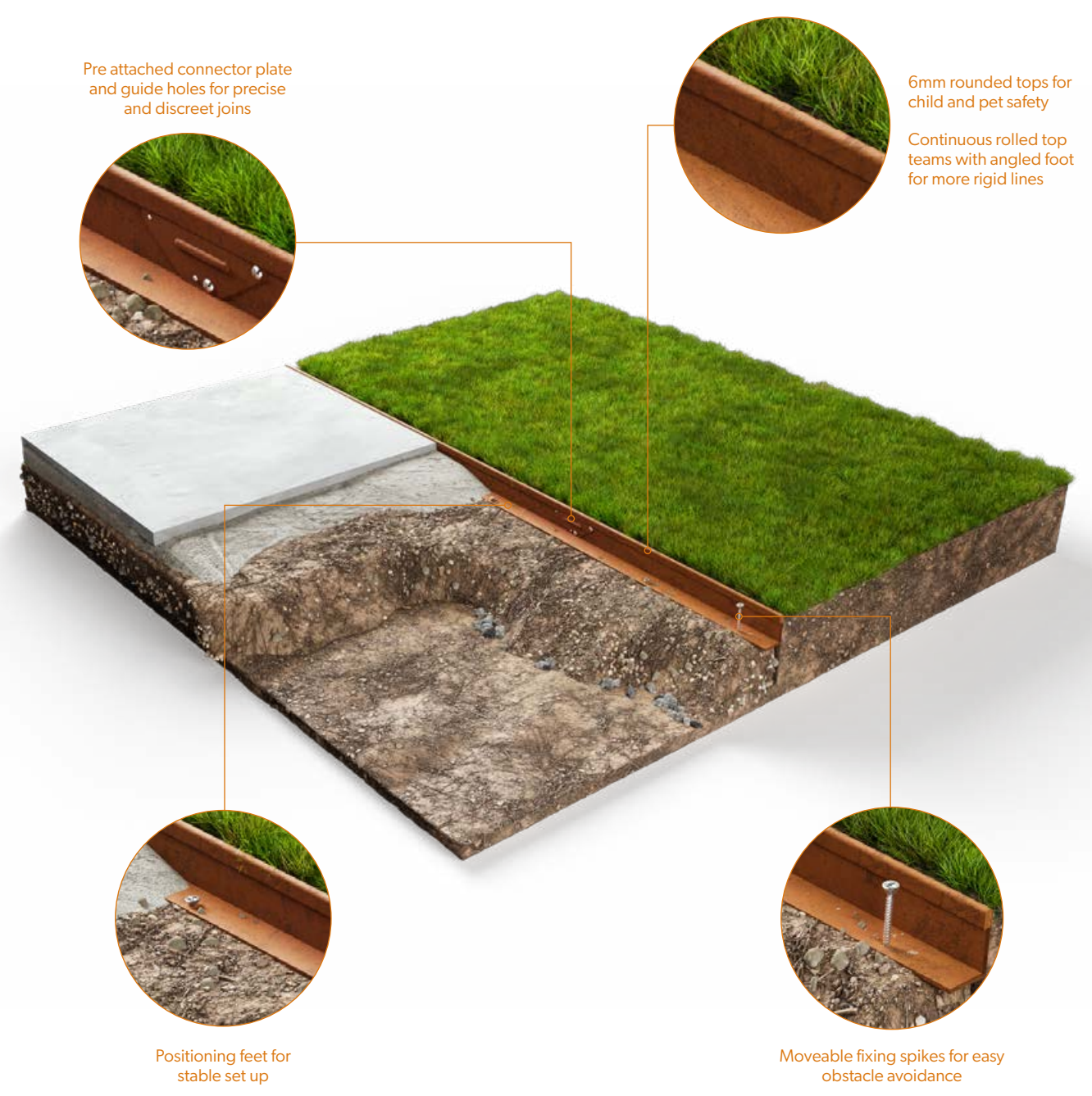

Product specifications

TECHNICAL SPECIFICATIONS

Length (Installed)	2200mm
Top edge thickness	6mm
Steel plate thickness	1.6mm
Weight per length	3.7kg

BULK BUYING

Pack quantity	70
Bulk pack weight inc. pallet	280kg

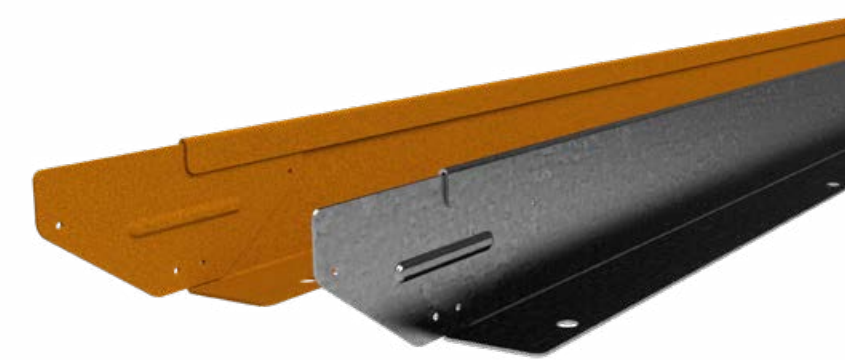

SOLD AS SET INCLUDING

- 1 x Connector plate (pre-attached)
- 3 x Galvanised spikes, 300mm long

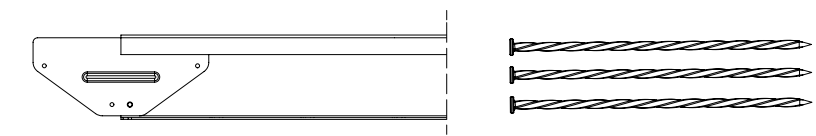

ADDITIONAL ACCESSORIES

- 500mm Corner piece (250 + 250mm arms, bend to desired angle)

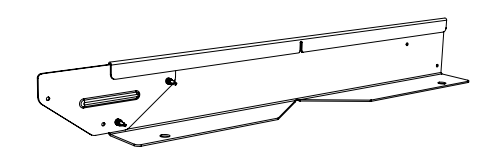

75mm Zero-Flex Installation Guide

Scan or click to watch install video



▶ INSTALL GUIDE

REQUIRED FIXINGS

- 2 x Tek Screws (12G x 16mm) or
- 2 x pop rivets (4mm shaft)

RECOMMENDED TOOLS

- Ground leveling tools
- Rubber mallet
- Cordless drill and Tek screw bit
- String line/line marking aid
- Angle grinder (required if modifying lengths or fashioning ends)

PREPARATIONS

Mark the intended line on the ground to measure what length of edge is needed. For a lower finishing height, make a shallow trench to partially bury the edge. A firm, level base is easier to work on, so if working on loose sand, wet down first. With the surface ready a string line or similar aid is useful to assist edge placement.

Note: This edge will not flex for gentle curves, it is for straight lines only.

DO...

- ✓ Consider the best edge orientation in terms of smooth face viewing.
- ✓ Ensure the install surface is levelled before installing.
- ✓ Join all lengths in place and check the line before finally fixing in position.
- ✓ Introduce or make corners where needed for a continuous top edge line.
- ✓ Use some spikes to hold partially in place while reviewing position.
- ✓ Use some 75mm Flex lengths if your design has some curved sections, they're compatible!

DON'T...

- ✗ Try to bend, instead use 75mm Flex for any curved sections.
- ✗ Accelerate rust with acids or salts.
- ✗ Leave a square top corner unsafely protruding at an end, cap or round it off with a grinder instead.

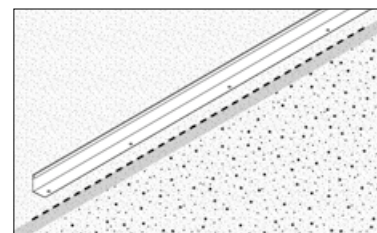

STEP 1 - Mark out edge line on ground and position edges on the desired line.

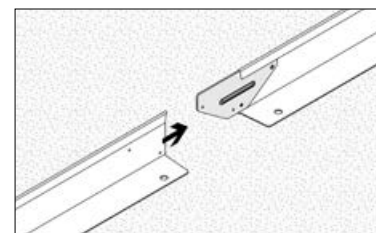

STEP 2 - Slide connector plate of one edge into the next to connect.

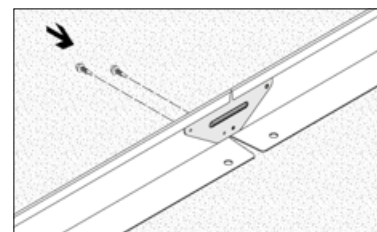

STEP 3 - Secure together with Tek screw through aligned guide holes.

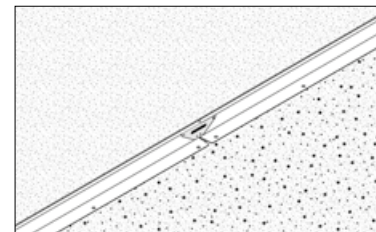

STEP 4 - Introduce further lengths, connecting them as you go.

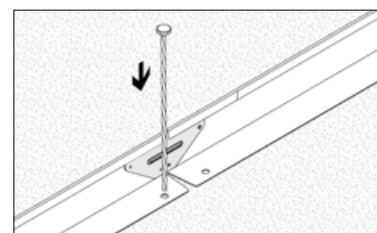

STEP 5 - Fix edge foot tabs with twisted nails in desired position.

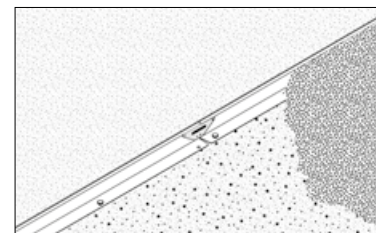

STEP 6 - Backfill to finish.

CORNERS - Corners are available for purchase or you can choose to make your own. Making your own corners will likely mean less waste, as the corners are simply made where they are needed with no offcuts created.

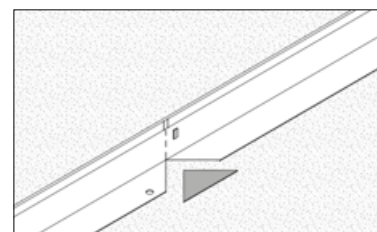

STEP 1 - Use angle grinder to score a line down the back of the edge and cut out these required gaps

i) 5-7mm of the folded lip at the top; and

ii) A wide triangular piece from foot (angle exceeding 90 degree)

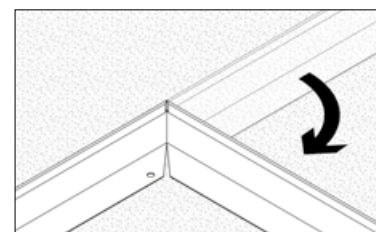

STEP 2 - Bend by hand (past the 90 then back for right angles) and perfect shape with rubber mallet.

GEOMETRIC SHAPES

You may look to create the likes of rectangles, squares or other linear shapes and patterns. To do so measure carefully and create the corners where needed.

When making basic corners, creating a foot gap larger than the space required allows you to bend past and return to the 90 degree angle which is helpful in getting it 'just right.'

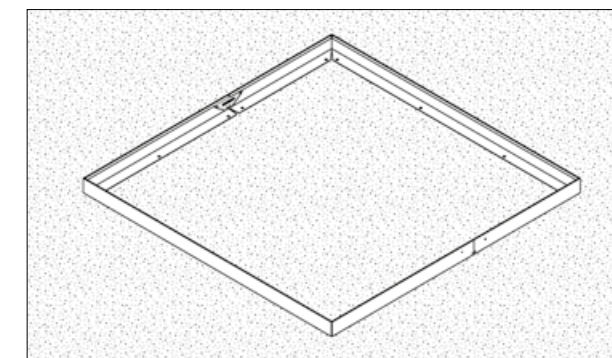

INSTALLING ON HARD SURFACES

The galvanised spikes will penetrate very hard ground, but use a bolt down option for concrete or other impenetrable surfaces. On impermeable surfaces use packers to elevate the edge slightly; allowing drainage away from edge.

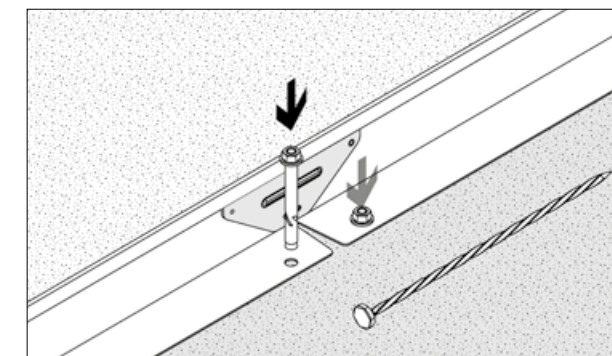

COMPATIBILITY

The 75mm Zero-Flex is compatible with the 75mm Flex, because the joining plates and edge profile are exactly the same. Where a layout requires straight sections and curved sections order some of each to best meet the design plan.

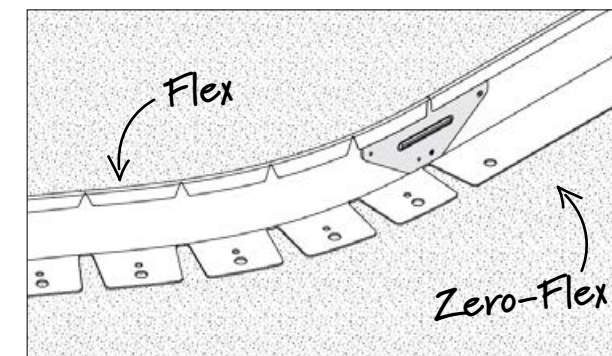

Technical Drawings



STRAIGHTCURVE® FLEX GARDEN EDGING - 75MM

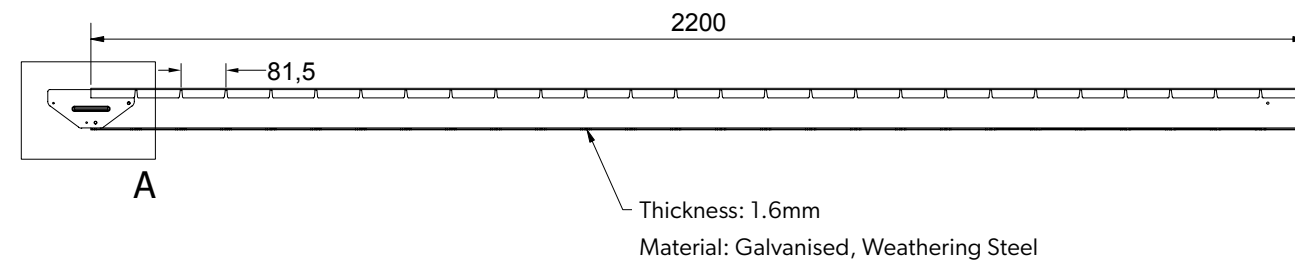

STRAIGHTCURVE® ZERO-FLEX GARDEN EDGING - 75MM

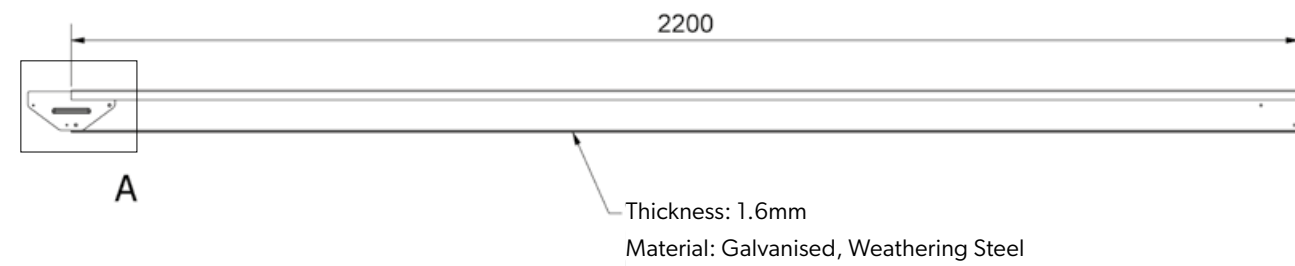

SIDE PROFILE

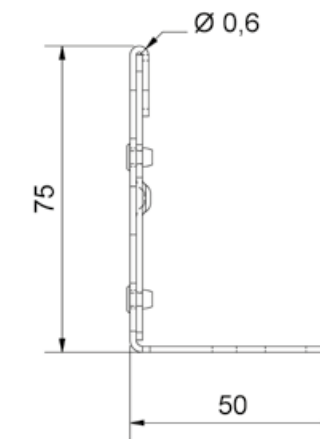

CONNECTOR PLATE

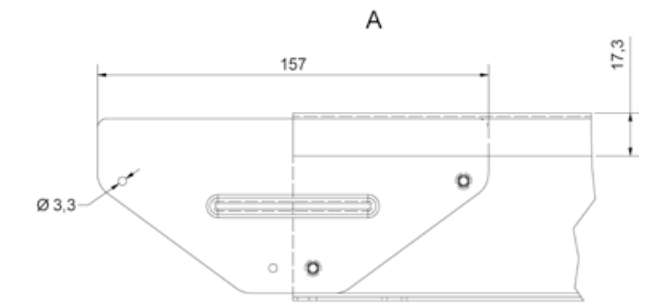

STRAIGHTCURVE® ZERO-FLEX GARDEN EDGING - 75MM - CORNER

