

Straightcurve® Zero-Flex Garden Edging - 100mm

HL100WS WEATHERING STEEL | HL100GS GALVANISED STEEL

EDGE STYLE

FINISHES

- Galvanised Steel
- Weathering Steel

For lasting, perfectly straight unmovable lines

Product features

The details that make the difference



Product specifications

TECHNICAL SPECIFICATIONS

Length (Installed)	2200mm
Top edge thickness	7mm
Steel plate thickness	1.6mm
Weight per length	6.4kg

BULK BUYING

Pack quantity	22
Bulk pack weight inc. pallet	160kg

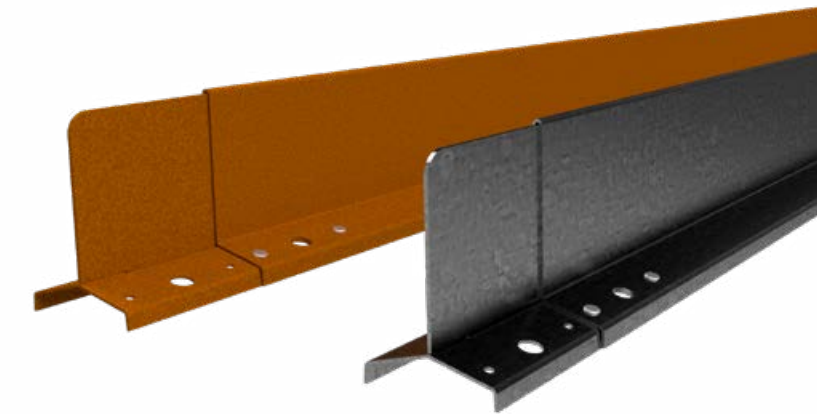

SOLD AS SET INCLUDING

- 1 x Connector plate (pre-attached)
- 4 x Galvanised spikes, 300mm long

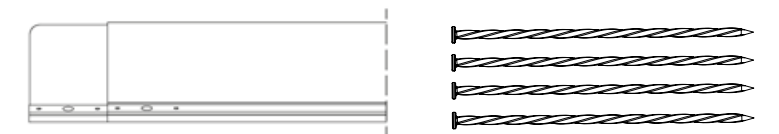

ADDITIONAL ACCESSORIES

- 500mm (250mm + 250mm) Corner piece (reversible) (bend to desired angle)

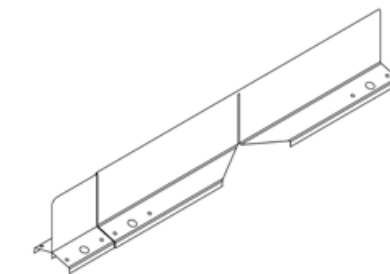

100mm

100mm

100mm Zero-Flex Installation Guide



REQUIRED FIXINGS

- 4 x Tek Screws (12G x 16mm) or
- 4 x pop rivets (4mm shaft)

RECOMMENDED TOOLS

- Ground leveling tools
- Rubber mallet
- Cordless drill and Tek screw bit
- Angle grinder (only required if modifying lengths or fashioning ends)

PREPARATIONS

Mark the intended line on the ground to measure what length of edge is needed.

A firmer, compacted base is best for installing Zero-Flex and may need to be prepared first. This foundation is key for the edges strength and line holding capability.

For a retrofit, where surrounding heights are set, trench relative to these. For a new garden where surrounding materials may be added, the edge is sometimes installed without a trench, and then materials are filled up to and around it. The trench depth dictates the amount of edge that finishes proud and visible. Burying the edge more deeply adds strength, as does having firm flat ground as the foundation. Consider the 150mm Zero-Flex if more visibility of edge face is desired.

DO...

- ✓ Pay attention to best ground preparation for a firm foundation
- ✓ Get the depth of trench right the first time
- ✓ Join all lengths and corners in place and perfect the line before finally fixing in position

DON'T...

- ✗ Use all galvanised spikes on one side only
- ✗ Skip the screwing stage, these lock in the seamless join
- ✗ Accelerate rust with acids or salts, that's harmful to patina development
- ✗ Leave a square top corner unsafely protruding at an end, cap or round it off with a grinder instead.

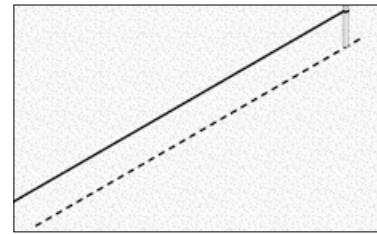

STEP 1 - Use string line or mark edge line on a firm base.

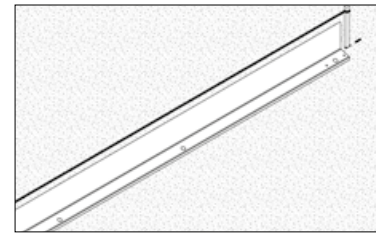

STEP 2 - Position first edges along the desired line.

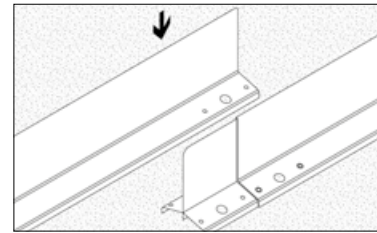

STEP 3 - Slide connector plate of one edge into the next to connect.

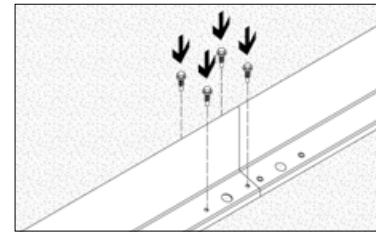

STEP 4 - Secure together with Tek screw through aligned guide holes.

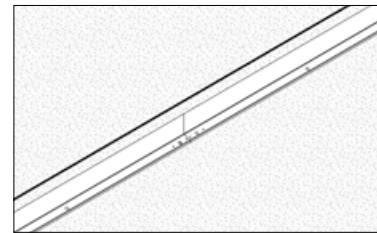

STEP 5 - Introduce further lengths, connecting them as you go along the install line.

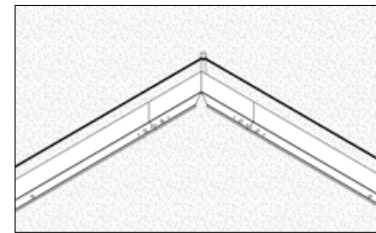

STEP 6 - Form and introduce corners where needed (lengths may need to be cut with grinder).

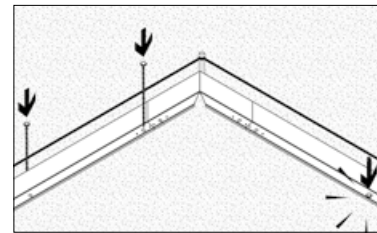

STEP 7 - Check position then hammer four galvanised spikes per length through foot holes, either side and evenly spaced.

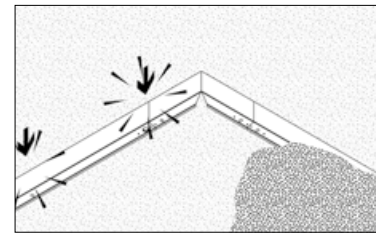

STEP 8 - Firing can be done with the rubber mallet, then backfill to finish

Bonus Tip! When is adding concrete footings a good idea?

For a Zero-Flex install on soft/sandy/shifting ground conditions consider setting the galvanised fixing spikes and the join sections into some concrete. Fill materials on both sides also add strength and can remove the need for concrete, but the foundation the edge sits on is always key to Zero-Flex's strength.

CORNERS

Standard corners are available for purchase, and their direction can be reversed when required by moving the connector plate to the other arm. Alternatively, you can choose to make your own corners. Making your own corners will likely mean less waste, as the corners are simply made where they are needed with no offcuts created.

Suggestion: Purchase one corner, and use that as a template for cutting in corners in other whole lengths where needed.

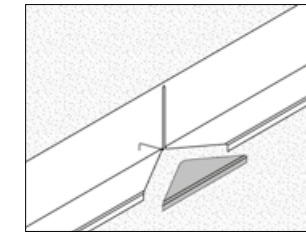

STEP 1 - Cut down the vertical wall (not to the very top) and cut away a V in the shoulder foot (at least 120 degrees) on the side where you will bend it in.

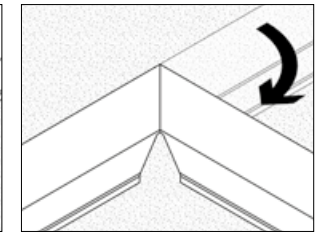

STEP 2 - Make a single cut on the opposing side shoulder (see step 1 diagram) then bend in the corner.

RECTANGLES & SQUARES

To create rectangles or squares be precise with your marking out before cutting. It's possible to join four corner pieces to easily make a 500mm x 500mm square. Similarly corners could be utilised with full lengths or part thereof, to make larger square or rectangular beds.

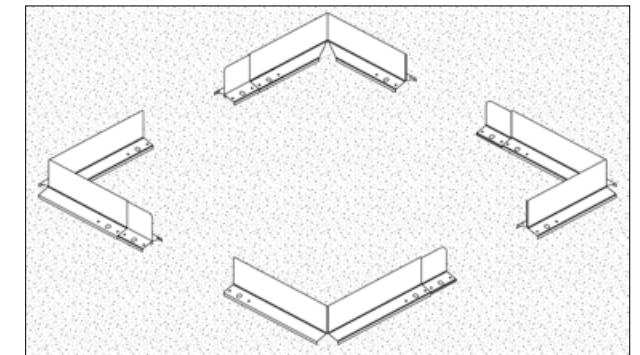

INSTALLING ON HARD SURFACES

The edge can be installed on a hard surface. When the surface is very hard but penetrable, use the galvanised spikes supplied. If the surface is impenetrable, such as concrete, a bolt down approach (purchase separately) can be applied. Utilise the same fixing holes but use packers to raise the edge slightly to allow drainage away from the edge.

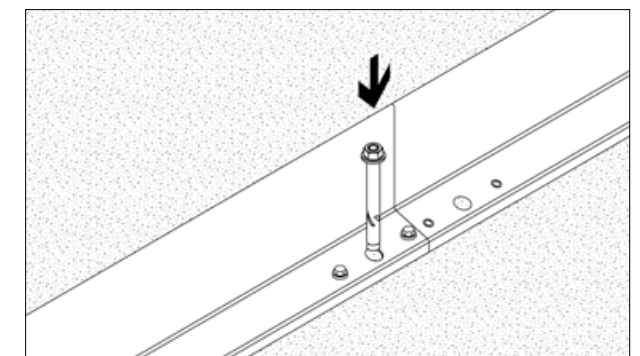

COMPATIBILITY

The Zero-Flex can have the equivalent height Flex product connected to it if a curved section is required. The top profiles are not exactly the same, but very similar when butted together. The Flex connector plate will slot into the Zero-Flex and would then need custom securing down low with some Tek screws.

Where the non-connector plate end of the flexline meets Zero-Flex Garden Edging (see adjacent pics), cut out a lower portion of the Flex edge to allow it to sit neatly onto the Zero-Flex edge connector plate and secure with screws.

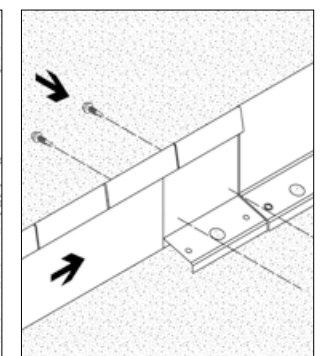
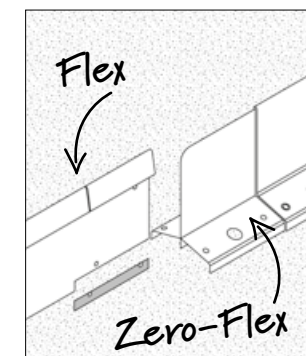

Technical Drawings



100mm

100mm

STRAIGHTCURVE® FLEX GARDEN EDGING - 100MM

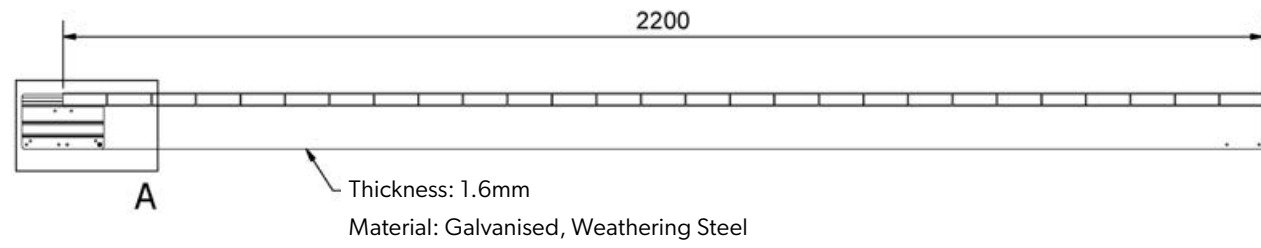

STRAIGHTCURVE® RIGID GARDEN EDGING - 100MM

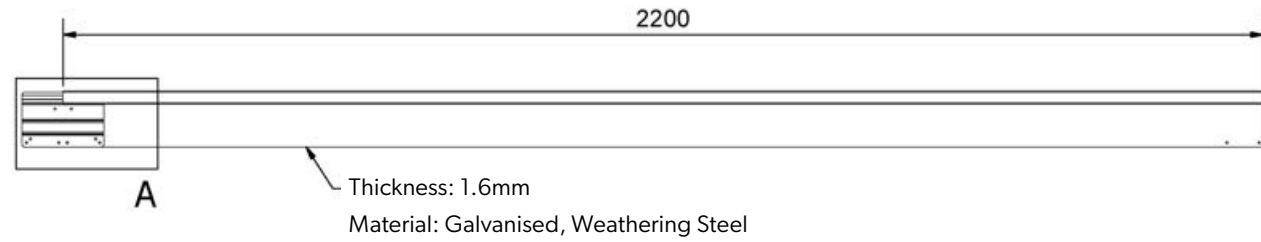

UNIVERSAL SPECIFICATIONS

SIDE PROFILE

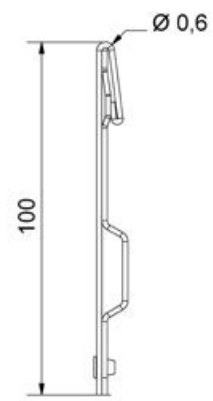

CONNECTOR PLATE

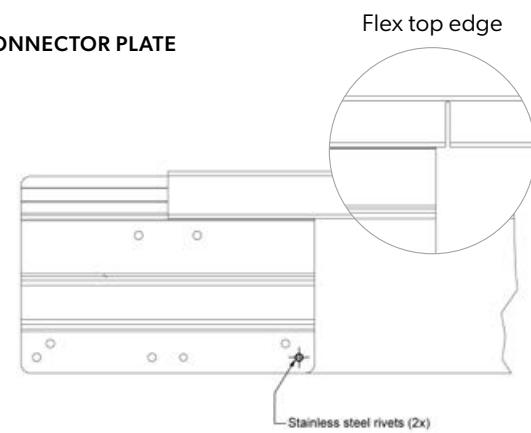

HARD SURFACE FIXING BRACKET

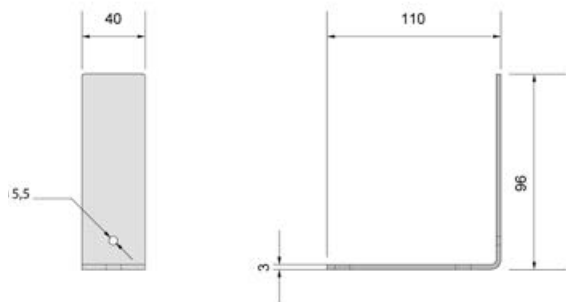

HEAVY DUTY PEG

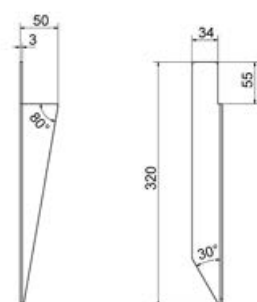

STRAIGHTCURVE® ZERO-FLEX GARDEN EDGING - 100MM

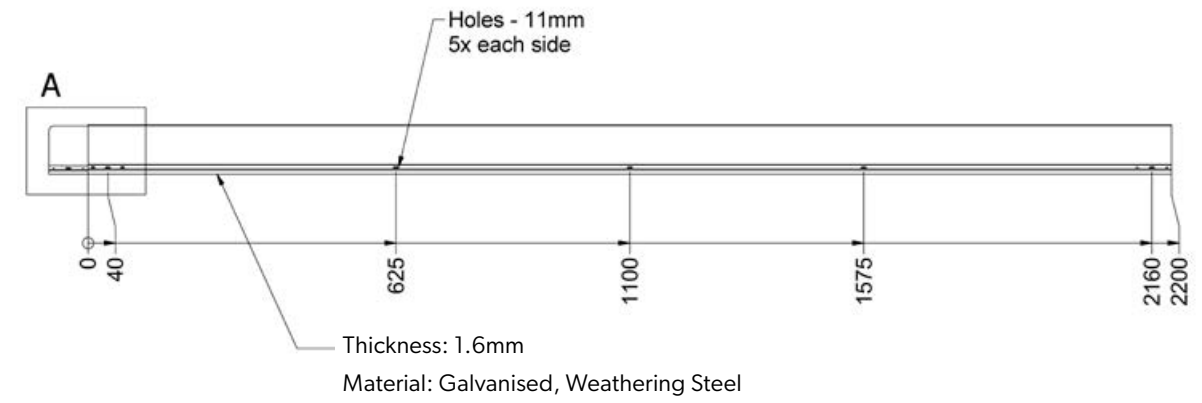

SIDE PROFILE

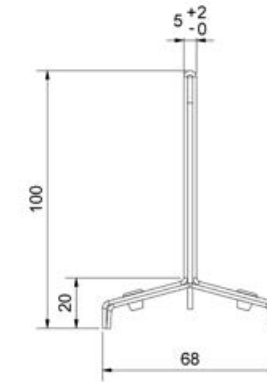

CONNECTOR PLATE

